

CURRENTS

4 | 6 | 2020

A publication of Newport News Shipbuilding



Lifting equipment that will be used to help disassemble the crane is lowered into a dry dock. Photo by Matt Hildreth

Crews Prepare to Disassemble Crane

Crews are preparing to disassemble Newport News Shipbuilding's green 310-long-ton Goliath gantry crane. One of the shipyard's iconic structures, it has stood at NNS for a half century.

"We're going to build a tower system in both dry docks that will pick up the whole crane, and then we'll start disassembling it from the bottom up," said Engineering Manager **Brian Jones** (O48).

About 3,000 tons of lifting equipment to support the project arrived by ship from Belgium in late March. The ship's crew was kept at sea for two extra days to satisfy the 14-day quarantine period to prevent the spread of COVID-19 before offloading could begin at NNS. The Coast Guard and NNS leadership also completed wellness checks with the crew.

Shipbuilders can expect to see four towers rise each in the two dry docks the crane straddles by the end of April. Lifting should begin in June, with completion expected in August.

After being disassembled, the crane will be scrapped, Jones said. According to a 1969 *Shipyards Bulletin* article, it was "the largest gantry crane of its type in the nation," when it was built at NNS.

The crane's successor – a 315-metric-ton Goliath gantry crane – officially came into service last fall.

NNS Allows Cloth Face Coverings; Other COVID-19 Updates

Based on new guidance from the Centers for Disease Control and Prevention on the use of cloth face coverings to prevent the spread of COVID-19, cloth face coverings are now allowed at Newport News Shipbuilding.

In addition to daily communications, NNS President **Jennifer Boykin** will share a weekly update each Friday summarizing the company's COVID-19-related actions. NNS also updated a list of frequently asked questions to the Liberal Leave Fact Sheet. For more information, visit nns.huntingtoningalls.com/411.

USS *Delaware* (SSN 791) Commissioned

The Navy commissioned the 18th *Virginia*-class submarine, USS *Delaware* (SSN 791), Saturday, April 4.

Restrictions on public gatherings in place to prevent the spread of COVID-19 forced the cancellation of the traditional public commissioning ceremony. However, the ship was commissioned administratively and transitioned to normal operations. Navy officials hope to celebrate *Delaware's* commissioning in the future with Ship's Sponsor Dr. Jill Biden, the crew and commissioning committee.

"The U.S. Navy values the support of all those who contributed to today's momentous milestone and will look for a future opportunity to commemorate this special event," said Vice Adm. Daryl Caudle, commander, Submarine Forces.

Built as part of a teaming agreement between Newport News Shipbuilding and General Dynamics Electric Boat, *Delaware* was christened at NNS in October 2018 and delivered to the Navy in October 2019.

Check NNS' Website for the Latest Coronavirus Updates

Newport News Shipbuilding provides daily updates about COVID-19 and company operations on nns.huntingtoningalls.com/411. The Employee Information Phone Line (1-877-871-2058) also provides up-to-date information about shipyard operations. Employees can call the Human Resources and Labor Relations Hotline (1-844-243-8749) or email COVID-19@hii-nns.com for Coronavirus questions or concerns.

NNS Fire Wardens are Vital

Newport News Shipbuilding's designated fire wardens have specific responsibilities that assist in the management of fire safety and the safety of building occupants in the event of an emergency.

"Our fire wardens provide an important service that protects the safety of all employees," said NNS Fire Chief **Mark McTheny**. "Their dedication and sacrifice is essential and should not be overlooked."

Changes instituted at NNS to help protect shipbuilders and their families during the COVID-19 pandemic have reduced the number of employees working in onsite buildings. However, McTheny said the role of fire wardens remains vital.

"Unless a particular facility is completely unoccupied, a fire warden is still required to be present and able to fulfill the duties of the position," he said. "Certain areas will require forward thinking to meet the responsibilities and placement for fire wardens."

For questions concerning the recommended number of fire wardens, how to obtain training for new fire wardens, and the expected interaction with emergency responders as they arrive, contact NNS Fire Marshal **Troy Long** at 688-5627. The Fire Prevention Office is available to support employees performing fire warden duties until official training can be scheduled or until the return of a designated fire warden.

NOTICE: Parking During Liberal Leave

As a reminder, open parking is in place at Newport News Shipbuilding during liberal leave, which is in place through April 30. Open parking means NNS employees, contractors and leased employees are able to park their vehicle in any parking space on company property. Vehicles must be parked legally. Open parking excludes lots and spaces identified as:

- Handicap
- 24-hour reserved
- Government and U.S. Navy
- HII Family Health Center
- Privately owned (including retail) and leased

HRT Accommodates Shipbuilders

Hampton Roads Transit modified its "essential service plan" Thursday, April 2, in response to the Coronavirus (COVID-19) pandemic. A Route 103 trip will depart from the Hampton Transit Center, at 5:15 a.m. Monday through Friday to provide service to Newport News Shipbuilding via Victoria Boulevard, Shell Road and Pembroke Avenue. NNS employees will not be penalized for limited ridership during liberal leave, and are encouraged to call (757) 222-6100 for updates or visit gohrt.com.

Virtual NNS 5K Planned

Due to measures put in place to prevent the spread of COVID-19, the 2020 Newport News Shipbuilding 5K will be a virtual event. Interested participants will have the chance to complete the 5K from home the weekend of June 6. Employees, friends and family members can participate. Those who register, complete the race and post their time will have a chance of winning a prize. Registration information is coming soon.

Visit myquadmedical.com/HII to sign up for the Go the Extra Mile Wellness Challenge and receive weekly emails, a training plan and tips leading up to the event. Anyone who logs at least 10 miles while training will be entered for a chance to win a FitBit Versa. All employees and family members on an HII health plan are eligible for the challenge. Registration opens Monday, April 6, and the challenge begins Monday, April 20.

NNS Cancels 2020 Internship Programs

As the Coronavirus (COVID-19) pandemic continues to evolve, Newport News Shipbuilding has canceled its 2020 summer internship programs to help prevent the spread of the virus. This includes the main internship, ABILITY, eShip/iShip and Trades internship programs. Students were notified Monday, April 6.

NNS' Talent Acquisition, Workforce Development and division intern project leads had worked for months to deliver a world-class internship program for more than 200 students.

As an alternative, the Talent Acquisition University Relations and Recruiting team will offer free virtual learning workshops during the summer on resume writing, interviewing and other topics to the students impacted by this decision. Opportunities for other available options with schools are being explored. Additionally, priority consideration will be given for co-op opportunities, 2021 summer internships, and full-time positions for those graduating in December 2020 or May 2021.

"This was a difficult decision to make" said **Jessica Hegeman**, manager of University Relations and Recruiting. "We understand how important our internships were for students in terms of summer employment and work experience, but also for our internal customers in building pipeline talent."

NOTICE: Disposal of Sanitizing Wipes

Newport News Shipbuilding's Facilities Maintenance Department reminds employees to dispose of sanitizing wipes in waste baskets. They should not be flushed in toilets. Wipes can get stuck in pipes and cause backups and overflows, which can cause restrooms to be out of service for extended periods of time. Only single seat covers and toilet paper should be disposed of in toilets.

Coronavirus (COVID-19) Communications

Use of Cloth Face Coverings at NNS



Newport News Shipbuilding
A Division of Huntington Ingalls Industries

April 5, 2020



CDC COVID-19 Guidance: Use of Cloth Face Coverings

The [Center for Disease Control and Prevention \(CDC\)](#) has adjusted their guidance on the use of cloth face coverings to prevent the spread of COVID-19 as follows:

Cover your mouth and nose with a cloth face cover when around others

- You could spread COVID-19 to others even if you do not feel sick.
- Everyone should wear a cloth face cover when they have to go out in public, for example to the grocery store or to pick up other necessities.
- Cloth face coverings should not be placed on young children under age 2, anyone who has trouble breathing, or is unconscious, incapacitated or otherwise unable to remove the mask without assistance.
- The cloth face cover is meant to protect other people in case you are infected.
- Do NOT use a facemask meant for a healthcare worker.
- Continue to keep about 6 feet between yourself and others. The cloth face cover is not a substitute for social distancing.

NNS will continue to follow the CDC's guidance to prevent the spread of COVID-19, including the use of cloth face coverings. Individuals using cloth face coverings at NNS must do so under the following guidelines:

- Must be removed so that your face can be seen at all access points (areas where you are required to scan your badge)
- Must be removed when requested by Security for identity verification
- Must be tight to the face with no loose edges when working around rotating equipment
- Cannot be worn with NNS-approved respirators
- Cannot be worn as a substitute for NNS-approved respirators
- Cannot be worn when performing hot work
- Must be disposed of properly in trash receptacles
- Face cloths are an additive protection – continue to practice social distancing

CDC Links:

[How to wear a face cover, homemade face covers, and cleaning and removal of face coverings](#)

Video: [How to make your own face covering](#)

Newport News Shipbuilding has established a public website to share the latest information and resources:

nns.huntingtoningalls.com/411

Based on new guidance from the CDC on the use of cloth face coverings to prevent the spread of COVID-19, cloth face coverings are allowed at Newport News Shipbuilding.

Use of Cloth Face Coverings to Help Slow the Spread of COVID-19

How to Wear Cloth Face Coverings

Cloth face coverings should—

- fit snugly but comfortably against the side of the face
- be secured with ties or ear loops
- include multiple layers of fabric
- allow for breathing without restriction
- be able to be laundered and machine dried without damage or change to shape

CDC on Homemade Cloth Face Coverings

CDC recommends wearing cloth face coverings in public settings where other social distancing measures are difficult to maintain (e.g., grocery stores and pharmacies), **especially** in areas of significant community-based transmission.

CDC also advises the use of simple cloth face coverings to slow the spread of the virus and help people who may have the virus and do not know it from transmitting it to others. Cloth face coverings fashioned from household items or made at home from common materials at low cost can be used as an additional, voluntary public health measure.

Cloth face coverings should not be placed on young children under age 2, anyone who has trouble breathing, or is unconscious, incapacitated or otherwise unable to remove the cloth face covering without assistance.

The cloth face coverings recommended are not surgical masks or N-95 respirators. Those are critical supplies that must continue to be reserved for healthcare workers and other medical first responders, as recommended by current CDC guidance.

Should cloth face coverings be washed or otherwise cleaned regularly? How regularly?

Yes. They should be routinely washed depending on the frequency of use.

How does one safely sterilize/clean a cloth face covering?

A washing machine should suffice in properly washing a cloth face covering.

How does one safely remove a used cloth face covering?

Individuals should be careful not to touch their eyes, nose, and mouth when removing their cloth face covering and wash hands immediately after removing.

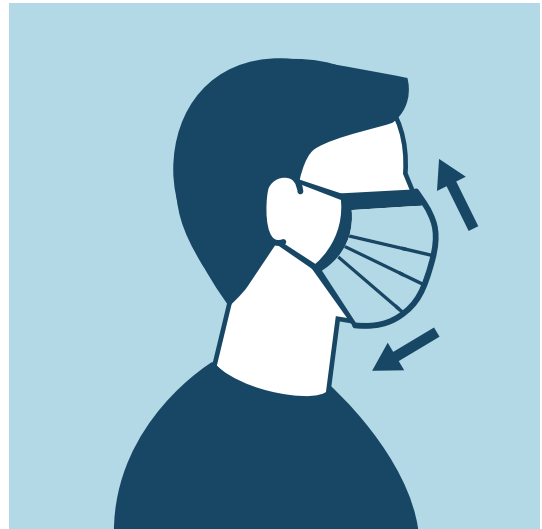

[cdc.gov/coronavirus](https://www.cdc.gov/coronavirus)

Newport News Shipbuilding has established a public website to share the latest information and resources:

nns.huntingtoningalls.com/411

Sewn Cloth Face Covering

Materials

- Two 10"x6" rectangles of cotton fabric
- Two 6" pieces of elastic (or rubber bands, string, cloth strips, or hair ties)
- Needle and thread (or bobby pin)
- Scissors
- Sewing machine

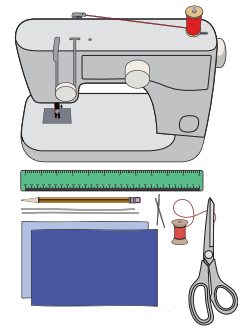

Tutorial

1. Cut out two 10-by-6-inch rectangles of cotton fabric. Use tightly woven cotton, such as quilting fabric or cotton sheets. T-shirt fabric will work in a pinch. Stack the two rectangles; you will sew the cloth face covering as if it was a single piece of fabric.

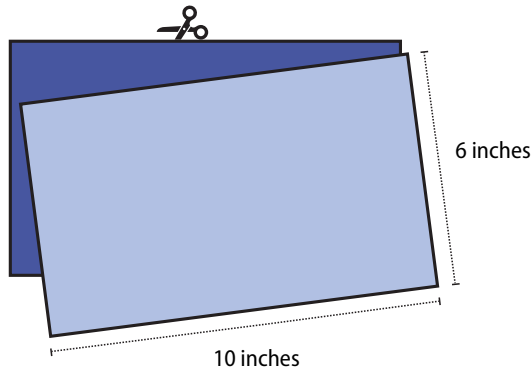

2. Fold over the long sides 1/4 inch and hem. Then fold the double layer of fabric over 1/2 inch along the short sides and stitch down.

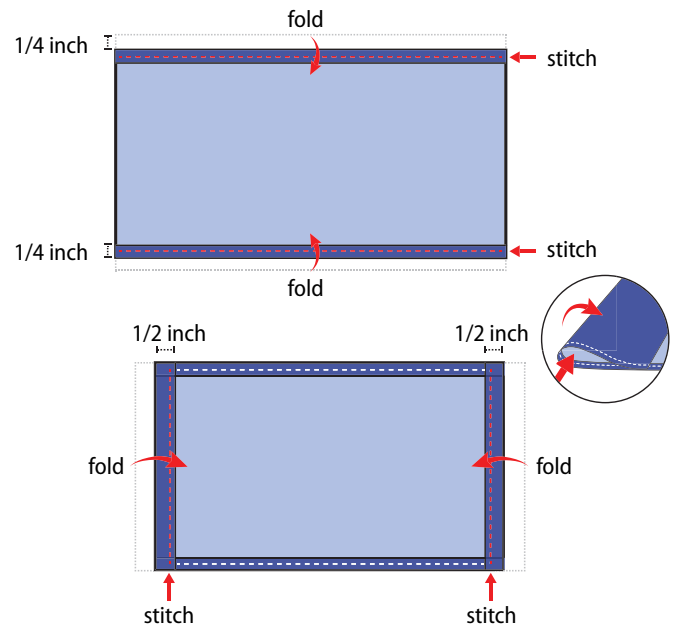

3. Run a 6-inch length of 1/8-inch wide elastic through the wider hem on each side of the cloth face covering. These will be the ear loops. Use a large needle or a bobby pin to thread it through. Tie the ends tight. Don't have elastic? Use hair ties or elastic head bands. If you only have string, you can make the ties longer and tie the cloth face covering behind your head.

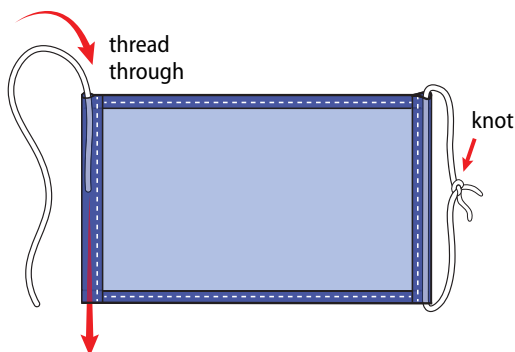

4. Gently pull on the elastic so that the knots are tucked inside the hem. Gather the sides of the cloth face covering on the elastic and adjust so the cloth face covering fits your face. Then securely stitch the elastic in place to keep it from slipping.

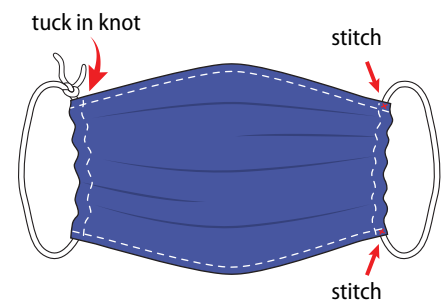

Quick Cut T-shirt Cloth Face Covering (no sew method)

Materials

- T-shirt
- Scissors

Tutorial

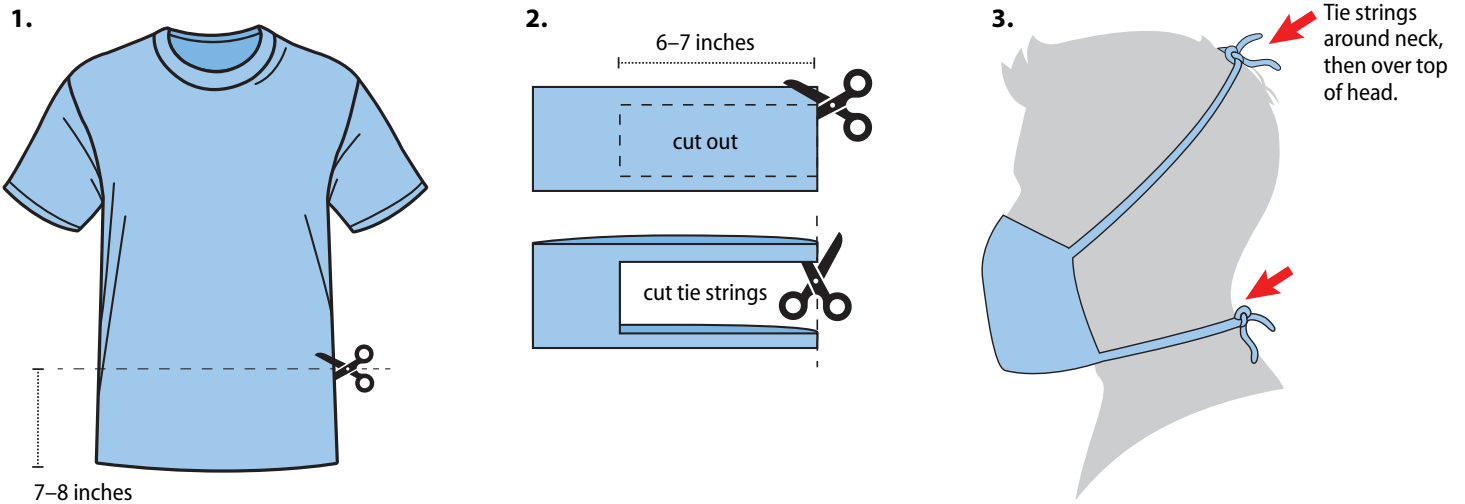

Bandana Cloth Face Covering (no sew method)

Materials

- Bandana (or square cotton cloth approximately 20"x20")
- Coffee filter
- Rubber bands (or hair ties)
- Scissors (if you are cutting your own cloth)

Tutorial

